

HOIST
ELEVATEUR
SEILWINDE
ELEVADOR ELECTRICO

SUM - SAT 210



*OPERATOR'S MANUAL
MANUEL DE MODE D'EMPLOI
BETRIEBSANLEITUNG
MANUAL DE INSTRUCCIONES*



Before using the hoist, read these instructions carefully and become familiar with the safety symbols. The handbook must always be kept together with the machine.

The contents of this use and maintenance manual conforms with EEC Machine Directive 89/392 and subsequent amendments. As the manufacturer, BETA reserves the right to make changes without prior notice and without being subject to any sanctions, **and also without affecting the commitment to respect the main safety technical characteristics.**



The symbol  represents a warning and indicates that the instructions must be carried out to prevent personal injury. Non-compliance with such instructions may lead to personal injury which, in some cases, may also be very serious.

WARRANTY

The company pledges, for 12 months from the hoist delivery date, to replace any defective parts, at no charge, provided that, based on an inspection performed by the technical centre, it is evident that the buyer has used the machine correctly, has complied with the use and maintenance standards contained in this manual and has not tampered or made changes to the machine.

The electric parts and the steel cable are excluded from the warranty.

For any repairs under warranty, the machine must be delivered, at the user's care and expense, to a Nuova BETA authorised service centre.

The manufacturer will not be responsible for any other damage, including the damage as a result of the non-use of the hoist.

PACKING AND TRANSPORT

The hoist is supplied packed in a special plastic bag.

The overall weight of the packed machine is 40 Kg (SUM) or 38 Kg (SAT).

At the time of purchase, the buyer must check that the machine is undamaged and includes all the necessary accessories (instruction manual, conformity declaration, warranty certificate).

The device must be handled with care using appropriate equipment and avoiding any type of impact.

In any case, the machine must be transported by two persons.

Before handling the device, the user must first check that:

- a) the cable is completely wound on the drum and the hook is attached to the machine structure
- b) the power supply outlet is disconnected.

MACHINE DESCRIPTION

**SUM 210 T-TC -SINGLE-PHASE HOIST MAXIMUM CAPACITY 200 KG.
SAT 210 T-TC -THREE-PHASE HOIST MAXIMUM CAPACITY 200 KG.**



The hoist has been designed and built to lift objects, materials or goods. ***It is absolutely prohibited to use the machine to lift persons and/or animals.***

CONSTRUCTION FEATURES

The hoist is equipped with an asynchronous, self-braking motor with a disk brake that is normally blocked by adequately sized tension springs.
It is also designed and built by Nuova BETA.
The hoist also includes a compact cascade reduction unit.

TECHNICAL FEATURES

The electric motor can be designed for different frequency and voltage values.

MOTOR

- A.C. asynchronous
- Self-braking with disk brake
- Closed version with external ventilation

REDUCTION UNIT

- Die-cast aluminium structure and supports
- Cylindrical gears
- Shafts mounted on ball bearings

TECHNICAL DATA	U.M.	SUM 210	SAT 210
Electric motor	Type	Single-phase	Three-phase
Motor power	kW	(1)	(1)
Voltage	V	(1)	(1)
Frequency	Hz	(1)	(1)
Current at peak load	A	(1)	(1)
Condenser	µF	(1)	-
Max. capacity	kg	200	200
Working length	m	25	25
Average lifting speed	m/min	~19	~19

(1) see attached circuit diagram.

The hoist is equipped with an electrical emergency lifting limit switch and it is also designed to install a parking brake on a stand.

CABLE FEATURES

Hoist	SUM-SAT 210
Material	Polished steel
Diameter and composition	5mm-133 wires
Elementary wire diameter	0.31-0.29 mm
Wire resistance	230-240 kg/mm
Minimum cable breaking load	1600 Kg
Minimum safety coefficient	8
Number of bearing sections	1

HOOK

Single with anti-release device

Capacity 750 kg

DRUM

Drum pitch diameter 80 mm

Safety devices: lifting limit switch with positive action control and in conformity with EN50047.

Noise emission: equivalent continuous acoustic pressure level measured under full load according to ISO 3746 (prEN 23746) is 80 dB (A).

INSTALLATION

The hoist can be installed as follows using special equipment manufactured by Beta:

- a) applied to a fixed structure attached by means of a special tie rod support.
- b) applied to a fixed structure by means of a special tie rod support plus a parallelogram.
- c) applied to a fixed structure by means of a special strut support.
- d) applied to a fixed structure by means of a special strut support plus a parallelogram.
- e) applied to a special tubular support structure with clamps.
- f) applied to a special ceiling or window strut support.
- g) mounted on a support stand.

If the hoist is installed according to methods (a,b,c,d,e,f) the user must follow the instructions listed below:

The uprights of the scaffolding, when the lifting equipment is attached directly to them, must be reinforced and braced to ensure a solid condition that is adequate to withstand the greater stress and strain forces.

With metallic scaffolding, there must be an adequate number of uprights, on which the hoists are directly attached, and, in any case, no less than two.

The rotating arms bearing the pulleys and any hoist drums must be solidly attached to the uprights using brackets with screw bolts supplied with a nut and counternut. The same situation is required for the cable transmission pulleys at the foot of the uprights when the drums are installed on the ground.

The hoists installed on the ground, in addition to being solidly anchored, must also be installed so that the cable unwinds from the lower part of the drum.

The operator of <<projecting>> hoists attached to scaffolding uprights, when guards cannot be attached to the sides and the front of the control position, must wear a safety belt.

The protection described in point "c" on page 13 must be applied even for the worker receiving the loads on the normal scaffolding.

For calculation purposes and to verify the stability, the forces acting on the wheels of the sliding trolley under the most severe load condition are reported (hoist with maximum capacity of 200 Kg).

The distance between the rest bushings at the fixing clamps is 300 mm

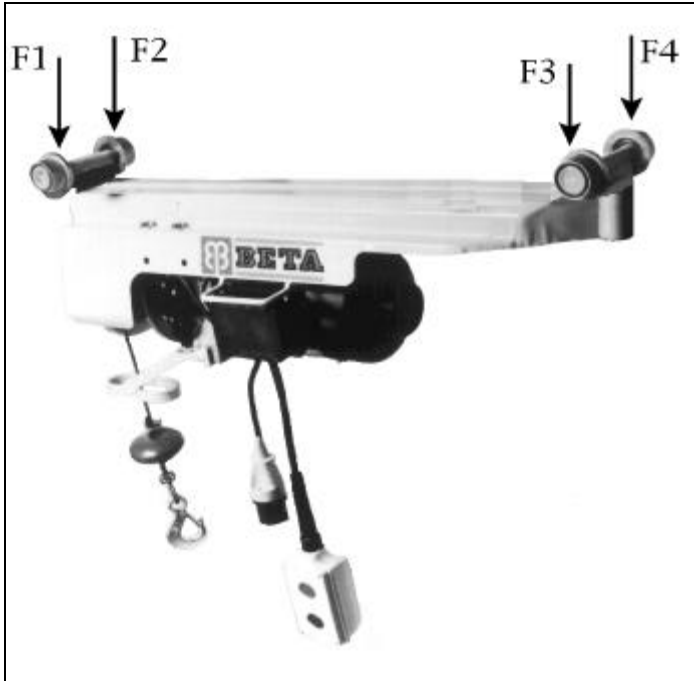

F1	1841N	188Kg
F2	678N	69Kg
F3	1270N	129Kg
F4	-474N	-48Kg

Case a) support with tie rod:

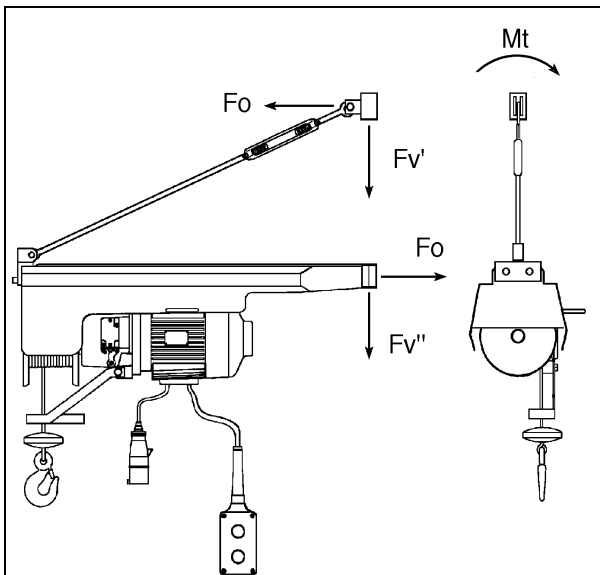

Fv'	2665N	272Kg
Fv''	365N	37Kg
Fo	7183N	732Kg
Mt	148Nm	15Kg

Case d) strut support plus parallelogram:

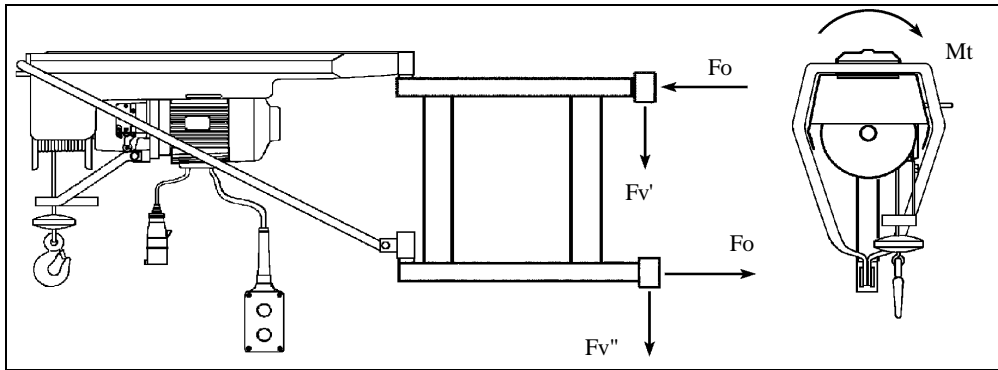

Fv'	1344N	137Kg
Fv''	1344N	137Kg
Fo	10192N	1039Kg
Mt	148Nm	15Kgm

Case e) tubular support with clamps:

The values are supplied of the bending moment M_f , twisting moment M_t , vertical component F_v determined by the load and the weight of the hoist. Whoever installs the machine must check that the structure on which the hoist is mounted is suitable to withstand the stress indicated below.

Hoist Installation with Tie Rod		
Fv	2682N	273Kg
Mf	2119Nm	216Kgm
Mt	148Nm	15Kgm

Hoist Installation with Strut		
Fv	2682N	273Kg
Mf	2119Nm	216Kgm
Mt	148Nm	15Kgm

Hoist Installation with Tie Rod or Strut + Parall.		
Fv	2682N	273Kg
Mf	3058Nm	312Kgm
Mt	148Nm	15Kgm

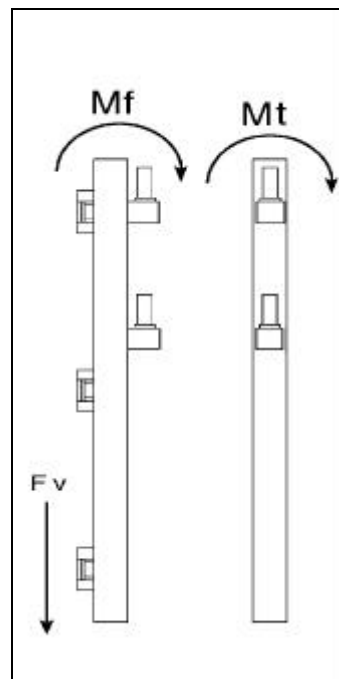

Case f) window or ceiling strut support:

In addition to the limiting reactions described in the figure, the hoist under a load condition generates a tilting moment M_r that must be balanced by placing the screw under tension, checking the support capacity of the floor, ceiling and/or wall structure.

The forces F_f'' and F_s'' reported in the table, refer to the worst possible load conditions (minimum strut length).

	Without parallelogram		With Parallelogram	
F_f'	2682N	273Kg	2682N	273Kg
F_f''	2018N	206Kg	2925N	298Kg
F_s'	2682N	273Kg	2682N	273Kg
F_s''	1695N	173Kg	2457N	250Kg
M_r	2119Nm	216Kgm	3071Nm	313Kgm
M_t	148Nm	15Kgm	148Nm	15Kgm

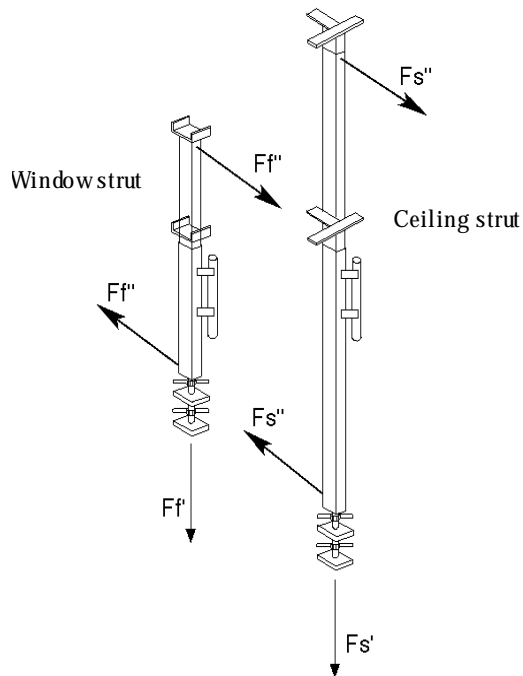

STAND



The hoist must be mounted on a stand with an adequate support capacity.

(A rating plate is attached to the sliding double rail indicating the maximum capacity).

The support stand consists of the parts reported in the diagram on page 21.

The structure must be assembled as shown in the above-mentioned diagram, checking that the connection nuts on the arches are tight (pos. 2-3), the double rail (pos. 1) and the bolts attaching the arch connection tie rods (pos. 4).



The tie rods must be used to stabilise the stand.

To use the hoist on the stand, the user must first stabilise the stand. It is absolutely prohibited to stabilise the stand in any way that differs from what is expressly stated below.



In particular, it is prohibited to use counterweights that are merely resting on or not permanently attached to the rear arch to prevent the structure from tipping.

The stand can be stabilised in one of the following two ways:

- a) Stabilisation using ballast containers

The two ballast containers, which can be supplied by the manufacturer, must be attached (using the special clamps) to the stand rear arch uprights as indicated in the assembly diagram.



The ballast in each container must have a minimum mass of 100 Kg.

In any case, the minimum useful volume of each of the two containers shall not be less than 0.10 m³.

The material to be inserted into the container must be solid, inert and its mass must have a volume that is greater than or equal to 1300 kg/m³.

The minimum overall mass of the two containers including ballast must be 256 Kg.

To check the resistance of the stand support surface, the forces exerted at the lower ends of the arches are reported considering the full containers for their entire capacity of a material with a mass whose volume is 1300 kg/m³ under the following load conditions:

- 1) hoist with load of 200 Kg in an internal position between the two arches (pos. M)
- 2) hoist with load of 200 Kg in a maximum projecting position (pos. N)

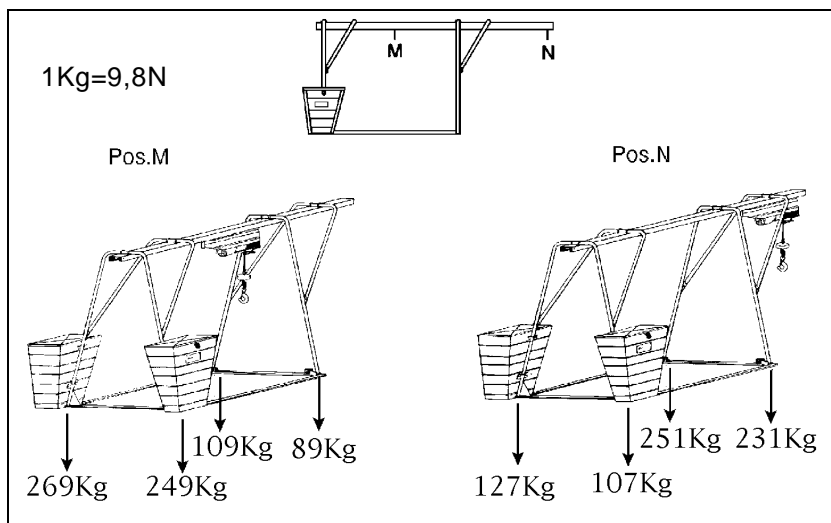

b) Stabilisation using anchors



The anchor must be made by connecting the rear arch of the stand to a stable structure using chains or brackets, according to the calculations and instructions supplied by a professionally qualified technician, who shall issue a special certification.

The forces exerted at the lower ends of the stand and those to be compensated to ensure stability are reported in the following tables, relative to the following two load conditions:

- 1) hoist with load of 200 Kg in an internal position between the two arches (pos. M)
- 2) hoist with load of 200 Kg in a maximum projecting position (pos. N)

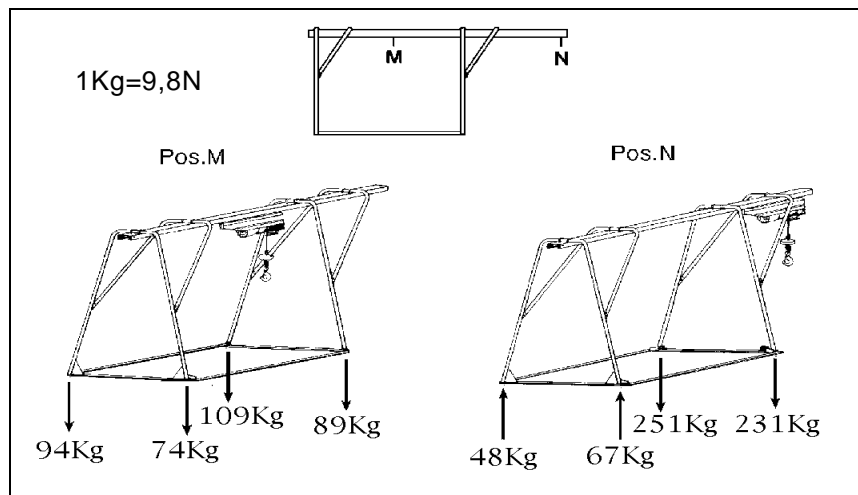

Based on the dimensions and type of load to be lifted, the device must be installed so that the load does not strike against other moving bodies or against stationary parts of the adjacent structures during the lifting and lowering movement.



The user must take all the necessary precautions, regardless of the type of installation created, to protect himself against the risk of falling.

In particular, the user must strictly comply with the following instructions:

- a- The scaffolding of the mountings must be sufficiently wide and, on the sides towards the empty space, equipped with a normal guard and toe board.
- b- An opening may be left to pass a shovel or bucket provided that a toe board with a height of no less than 30 cm is installed at that point. The opening must be reduced to what is strictly necessary and delimited by strong and rigid side supports, for which the one opposite to the pulling position must be additionally protected with fixed scaffolding elements.
- c- Two iron brackets, projecting at least 20 cm, must be applied on the inner side of the supports described above, at a height of 1.20 m and perpendicular to the opening, which will be used as a support and guard for the worker.
- d- The boards of the single shelves must be formed with planks with a thickness of no less than 5 cm which must rest on the cross members and have a section and centre distance that are sized in relation to the maximum load foreseen for each of the shelves.

At the end of the stand stabilisation operation, the hoist can be mounted as follows:

mount the parking brake on the crane ways as shown in the diagram on page 20. Remove the stop device located in the rear part of the sliding beam and insert the hoist wheels. Then replace the stop device.

START-UP AND USE



The machine should only be used by workers 14 years of age or older with an average skill level. It is recommended to use the machine in areas that are adequately illuminated.

In any case, check that:



a) the electric power supply corresponds to what is indicated on the rating plate attached to the casing of the electric motor;

Legend	
Type	Model
No.	Serial number
V	Power supply voltage
Hz	Frequency
rpm	Revolutions per minute
I.C.	Insulation class
A	Current intensity
KW	Power
C	Condenser capacity
CLASS	Class
DUTY	Load condition

BETA		CE
BETA ELEVATORI s.r.l. Via Edison 5 - 42040 Caldero RE		
Type	<input type="text"/>	
N=	<input type="text"/>	
CLASS	<input type="text"/>	
SELF BRAKING MONO-PHASE MOTOR		
Y	Hz	rpm
<input type="text"/>	<input type="text"/>	<input type="text"/>
A	Kw	c
<input type="text"/>	<input type="text"/>	<input type="text"/>
DUTY		<input type="text"/>
MAX HANGING LOAD		Kg <input type="text"/>

Legend	
Type	Model
No.	Serial number
V	Power supply voltage
Hz	Frequency
rpm	Revolutions per minute
I.C.	Insulation class
A	Current intensity
KW	Power
CLASS	Class
DUTY	Load condition

BETA		CE
BETA ELEVATORI s.r.l. Via Edison 5 - 42040 Caldero RE		
TYPE	<input type="text"/>	CLASS <input type="text"/>
N=	<input type="text"/>	
SELF BRAKING THREE-PHASE MOTOR		
rpm	Hz	I.C.
<input type="text"/>	<input type="text"/>	<input type="text"/>
Kw	Y _Δ	A
<input type="text"/>	<input type="text"/>	<input type="text"/>
Y 220	Y 380	
<input type="text"/>	<input type="text"/>	<input type="text"/>
MAX HANGING LOAD		Kg <input type="text"/>



b) the outlet used is the safety type and that it includes a ground pin that comes in contact with the pin on the plug supplied with the device;



c) the outlet is connected to an efficient ground system and that it is fed by an electric plant protected by a residual current circuit-breaker and high-sensitivity magnetothermal switch (0.03A), all coordinated to conform with the prescriptions set forth by UNICEI EN 60204/1 Sept. 93 (see attached circuit diagram). The switch must be installed on the power supply line prior to and in the vicinity of the machine;



d) the power supply cable section is adequate for the length of that cable to avoid an excessive voltage drop that might lead to malfunctions.
Indicatively, a section of 2.5 mm² should be used for distances of less than 30 m.
For greater distances, use cables with a section that is greater than or equal to 4 mm².

The hoist is controlled through a special control panel which includes two SALITA-DISCESA buttons as shown in the following diagram:

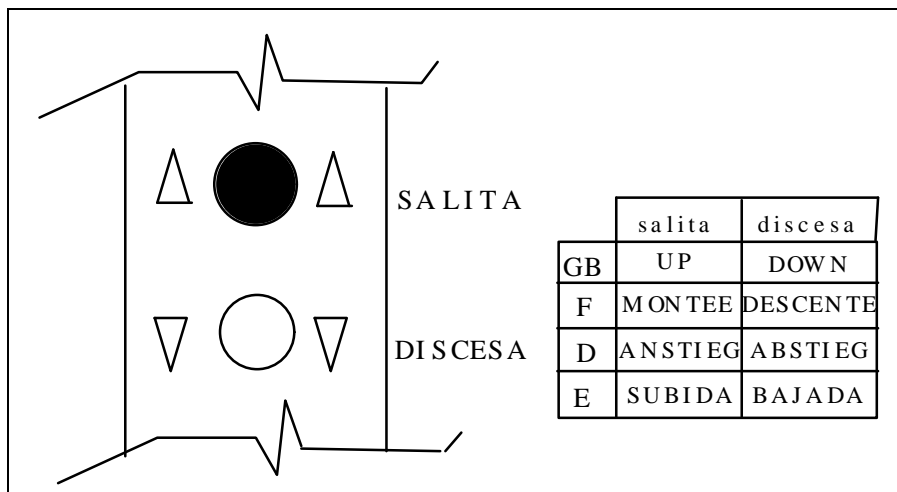

For the three-phase asynchronous motor version, check that the load is in fact lifted by pressing the corresponding “SALITA”-“UP” button located on the push-button panel.

If this does not occur, switch the two phase wires in the power supply outlet.

A machine (lifting-lowering) test cycle must be performed (under no load and then rated load conditions), checking that the lifting limit switch operates correctly and that the stand is stable.

Check that the lifting limit switch operates correctly at the beginning of each work shift.

The load braking system must be checked every six months and, in any case, each time that, during normal machine use, the load does not stop immediately.



It is absolutely prohibited to disassemble or access the internal parts of the hoist without first cutting off the power supply by pulling the plug out of the power outlet.

The operator must work in a safe position, i.e. so that he is protected against falling and so that he has an unobstructed view of the trajectory of the moving elements.

If the operator uses safety belts to protect himself against falling, they must be anchored to fixed parts and absolutely immovable.



The hoist stand, the ceiling or window strut or any other part of the machine support structure cannot be used as an anchor point for safety belts.

- Access to the area underneath the vertical axis of the load must be prohibited to persons or at least a sign must indicate the danger due to suspended loads.

The user must still check that there are no persons in the area underneath the vertical axis of the load.



The loads must be lifted with a vertical pull and therefore it is prohibited to use the hoist with an oblique lift.

- It is recommended to sling the load perfectly and to use adequate containers for liquid or sandy substances.

- It is prohibited to use the lifting cable to sling the load (see drawing).

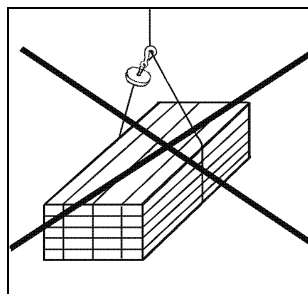

- It is prohibited to grab or touch the lifting cable while lifting or lowering the load, in particular near the lifting limit switch.

- The machine is built with an IP44 motor meaning that it is protected against solid bodies with sizes that are greater than one millimetre and against water infiltration in all directions.

Therefore, it is prohibited to use the machine in environments that are saturated with gas or if exposed to direct streams of water or rain.

- It is also recommended to:

a) avoid overloading the hoist;

- b) stop the lifting movement before the limit switch trips since it should only be used in case of emergency;
- c) check that the voltage does not decrease excessively during the start-up phase (this may prevent the brake from opening);



d) make sure that the cable does not completely unwind; at least 2 turns of the cable must remain on the drum to avoid damage due to the direct action of the load on the clamp that attaches the cable.

The cable wound on the hoist drum has a length that is greater than the maximum foreseen use height.

e) (using the special set screw) place the rotation shaft of the cable winder drum in a horizontal position to guarantee that the cable will be correctly wound on the drum.

f) The cable maximum winding diameter must guarantee a free space on the sides of the drum equal to 1,5 times the cable diameter.

Note: The manufacturer declines all responsibility for injury to persons or damage to property as a result of non-compliance with the above-mentioned standards.

MAINTENANCE

The entire device is built with class A4 which corresponds to 84000 operating Cycles.

The mechanism are built with class M4 which corresponds to 3200 h of operation.

After the number of operating cycles described above, the machine must be overhauled at a Nuova BETA authorised service centre.

The machine must be periodically inspected (on a six-month or yearly basis) to check the general use conditions (e.g. leaking grease, condition of electric power supply cables and machine control components, condition of the support structure, etc.).

In particular:

- The cables must be checked every three months and replaced immediately if there are any breaks in the elementary wires, or if they are twisted, smashed, bent, if knots have formed or if there is any other serious deterioration (heavy rust formation) or if heavily worn.
- The above-mentioned inspections must be reported on a special chart (see page 19), indicating the date of the inspection and the signature of the tester.
- The braking system must be checked every six months and, in any case, each time that, during normal machine use, the load does not stop immediately.
- The distance between the brake disk and electromagnets is adjusted using the set nut located at the end of the motor shaft.
It must range between 0.3-0.5 mm.
- The cable, hook and braking system register must be replaced by skilled personnel or at a BETA service centre.

REPAIRS

Repairs may be performed at a BETA service centre.

The user can request a list of authorised service centres at any time from dealers or directly from the manufacturer.

REQUEST FOR SPARE PARTS

A special manual includes tables with the drawings and the names of the various parts of the hoist. The code number is indicated next to the name of each part.

The request for spare parts must be submitted to a BETA service centre or to a dealer.

It must include the following:

- a) hoist model and serial number;
- b) piece position number or relative code;
- c) quantity requested.

WHEEL AND PARKING BRAKE ASSEMBLY

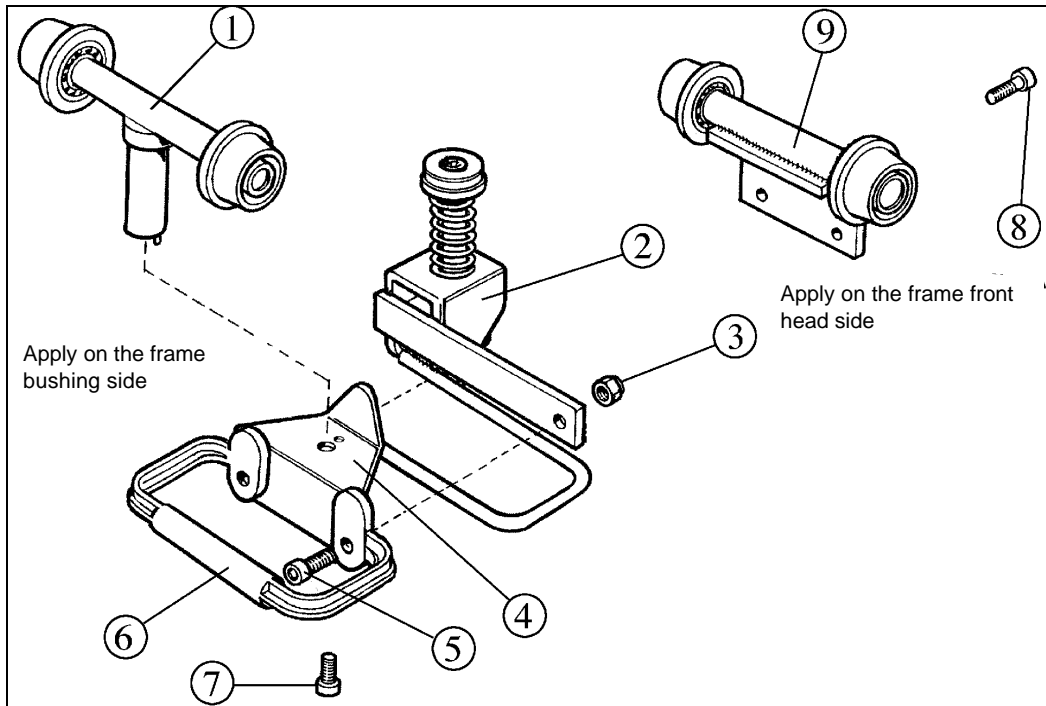

To correctly assemble the unit, following the instructions listed below in the order presented:

- insert the item marked with the number (1) into the frame bushing
- using the screw (7) attach the plate (4) to the item (1) inserting the reference pin into the relative hole
- with the screw (5) and the nut (3), attach the handle (6) to the brake unit (2) as shown in the diagram
- attach the item (9) with the screw (8) to the frame using the threaded holes already present.

STAND CHARACTERISTICS

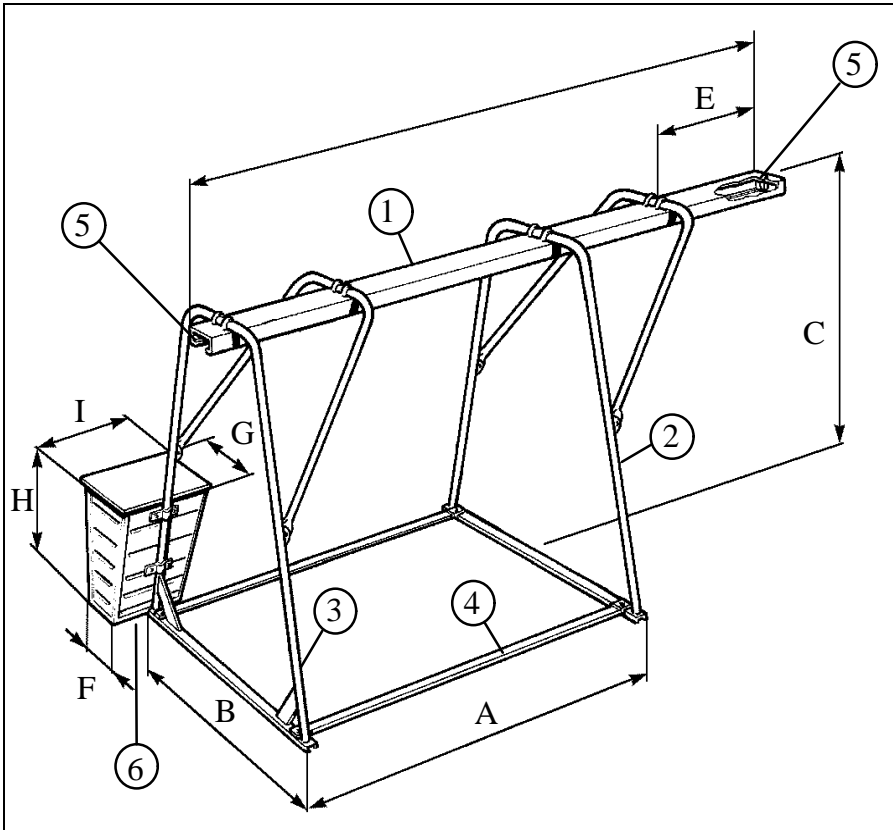

DIMENSIONS	POS.	NAME	Qty.
A = 2150	1	DOUBLE RAIL	1
B = 1520	2	FRONT ARCH	1
C = 2065	3	REAR ARCH	1
D = 3305	4	TIE RODS	2
E = 385	5	PLUGS	3
F = 285	6	BALLAST CONT.	2
G = 520			
H = 860			
I = 645			