

HOIST
ELEVATEUR
SEILWINDE
ELEVADOR ELECTRICO

SAM - SAT 300/600



*OPERATOR'S MANUAL
MANUEL DE MODE D'EMPLOI
BETRIEBSANLEITUNG
MANUAL DE INSTRUCCIONES*



Before using the hoist, read these instructions carefully and become familiar with the safety symbols. The handbook must always be kept together with the machine.

The contents of this use and maintenance manual conforms with EEC Machine Directive 89/392 and subsequent amendments. As the manufacturer, BETA reserves the right to make changes without prior notice and without being subject to any sanctions, **and also without affecting the commitment to respect the main safety technical characteristics.**



The symbol  represents a warning and indicates that the instructions must be carried out to prevent personal injury. Non-compliance with such instructions may lead to personal injury which, in some cases, may also be very serious.

WARRANTY

The company pledges, for 12 months from the hoist delivery date, to replace any defective parts, at no charge, provided that, based on an inspection performed by the technical centre, it is evident that the buyer has used the machine correctly, has complied with the use and maintenance standards contained in this manual and has not tampered or made changes to the machine.

The electric parts and the steel cable are excluded from the warranty.

For any repairs under warranty, the machine must be delivered, at the user's care and expense, to a Nuova BETA authorised service centre.

The manufacturer will not be responsible for any other damage, including the damage as a result of the non-use of the hoist.

PACKING AND TRANSPORT

The hoist is supplied packed in a special plastic bag.

The overall weight of the packed machine is 56 Kg (SAM) or 51 Kg (SAT).

At the time of purchase, the buyer must check that the machine is undamaged and includes all the necessary accessories (instruction manual, conformity declaration, warranty certificate).

The device must be handled with care using appropriate equipment and avoiding any type of impact.

In any case, the machine must be transported by two persons.

Before handling the device, the user must first check that:

- a) the cable is completely wound on the drum and the hook is attached to the machine structure
- b) the power supply outlet is disconnected.

MACHINE DESCRIPTION

SAM-SAT 300 Z/ZP -SINGLE/THREE-PHASE HOIST MAXIMUM CAPACITY 300 KG.



The hoist has been designed and built to lift objects, materials or goods. ***It is absolutely prohibited to use the machine to lift persons and/or animals.***

CONSTRUCTION FEATURES

The hoist is equipped with an asynchronous, self-braking motor with a disk brake that is normally blocked by adequately sized tension springs.

It is also designed and built by Nuova BETA.

The hoist also includes a compact cascade reduction unit.

TECHNICAL FEATURES

The electric motor can be designed for different frequency and voltage values.

MOTOR

- A.C. asynchronous
- Self-braking with disk brake
- Closed version with external ventilation

REDUCTION UNIT

- Die-cast aluminium structure and supports
- Cylindrical gears
- Shafts mounted on ball bearings

TECHNICAL DATA	U.M.	SAM 300	SAT 300
Electric motor	Type	Single-phase	Three-phase
Motor power	kW	(1)	(1)
Voltage	V	(1)	(1)
Frequency	Hz	(1)	(1)
Current at peak load	A	(1)	(1)
Condenser	µF	(1)	-
Max. capacity	kg	300	300
Working length	m	25	25
Average lifting speed	m/min	~20	~20

The hoist is equipped with an electrical emergency lifting limit switch and it is also designed to install a parking brake on a stand.

(1) see attached circuit diagram.

CABLE FEATURES

Hoist	SAM-SAT 300
Material	Polished steel
Diameter and composition	6mm-133 wires
Elementary wire diameter	0.40 mm
Wire resistance	200 kg/mm
Minimum cable breaking load	2400 Kg
Minimum safety coefficient	8
Number of bearing sections	1

HOOK

Single with anti-release device

Capacity 750 kg

DRUM

Drum pitch diameter 156 mm

Safety devices: lifting limit switch with positive action control and in conformity with EN50047.

Noise emission: equivalent continuous acoustic pressure level measured under full load according to ISO 3746 (prEN 23746) is 85 dB (A).

INSTALLATION

The hoist can be installed as follows using special equipment manufactured by Beta:

- a) mounted on a support stand.
- b) applied to a support stand (which may be equipped with crane ways) built by the user.

In the latter case, the user must submit a calculation report for the support stand, prepared by a qualified technician.

For calculation purposes and to verify the aforementioned structure, the forces acting on the wheels of the sliding trolley under the most severe load condition are reported (hoist with maximum capacity of 300 Kg).

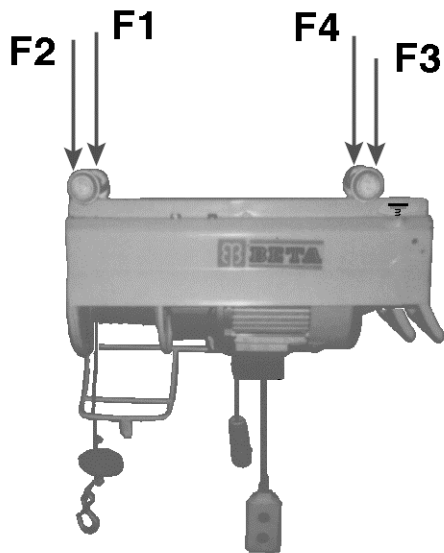

Type ZP

F1	706N	72Kg
F2	3210N	327Kg
F3	1040N	106Kg
F4	-810N	-82Kg

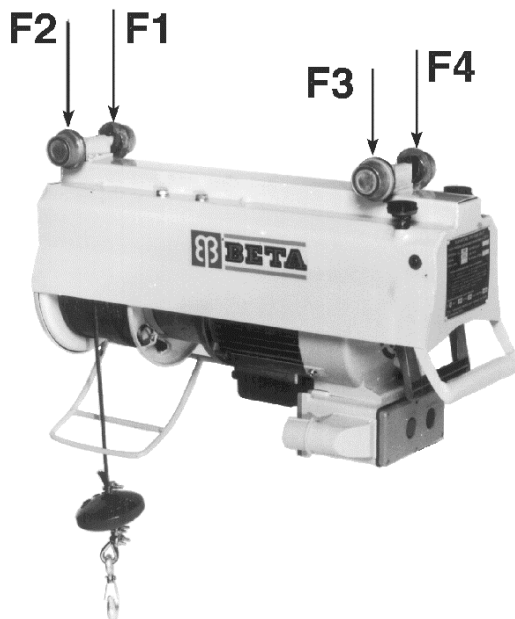

Type Z

F1	706N	72Kg
F2	3210N	327Kg
F3	1040N	106Kg
F4	-810N	-82Kg

To use the hoist on a support stand, the user must first stabilise such a stand by following the procedures described below.

STAND



The hoist must be mounted on a stand with an adequate support capacity.

(A rating plate is attached to the sliding double rail indicating the maximum capacity).

The support stand consists of the parts reported in the diagram on page 17.

The structure must be assembled as shown in the above-mentioned diagram, checking that the connection nuts on the arches are tight (pos. 2-3), the double rail (pos. 1) and the bolts attaching the arch connection tie rods (pos. 4).



The tie rods must be used to stabilise the stand.

It is absolutely prohibited to stabilise the stand in any way that differs from what is expressly stated below.



In particular, it is prohibited to use counterweights that are merely resting on or not permanently attached to the rear arch to prevent the structure from tipping.

The stand can be stabilised in one of the following two ways:

a) Stabilisation using ballast containers

The two ballast containers, which can be supplied by the manufacturer, must be attached (using the special clamps) to the stand rear arch uprights as indicated in the assembly diagram.



The ballast in each container must have a minimum mass of 150 Kg.

In any case, the minimum useful volume of each of the two containers shall not be less than 0.12 m³.

The material to be inserted into the container must be solid, inert and its mass must have a volume that is greater than or equal to 1300 kg/m³.

The minimum overall mass of the two containers including ballast must be 354 Kg.

To check the resistance of the stand support surface, the following tables report the forces exerted at the lower ends of the arches considering the full containers for their entire capacity of a material with a mass whose volume is 1300 kg/m³ under the following load conditions:

- 1) hoist with load of 300 Kg in an internal position between the two arches (pos. M)
- 2) hoist with load of 300 Kg in a maximum projecting position (pos. N)

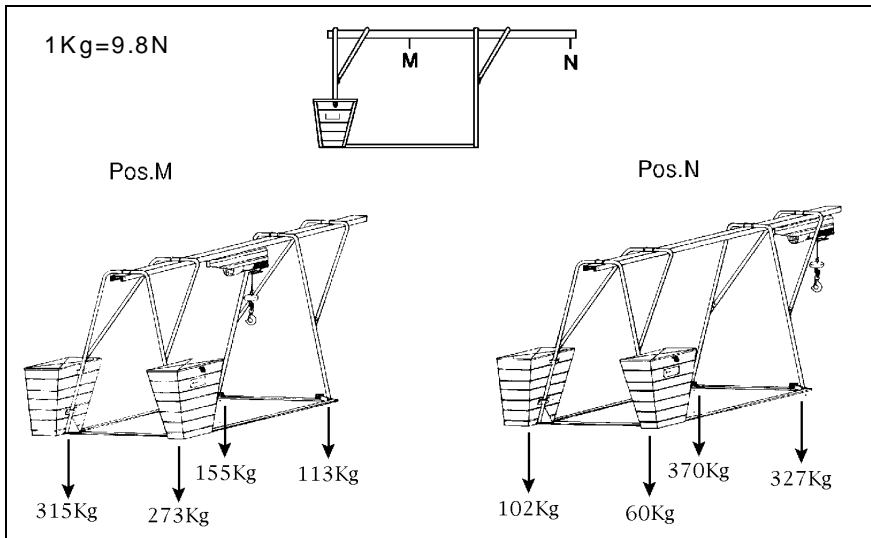

b) Stabilisation using anchors



The anchor must be made by connecting the rear arch of the stand to a stable structure using chains or brackets, according to the calculations and instructions supplied by a professionally qualified technician, who shall issue a special certification.

The forces exerted at the lower ends of the stand and those to be compensated to ensure stability are reported in the following tables, relative to the following two load conditions:

- 1) hoist with load of 300 Kg in an internal position between the two arches (pos. M)
- 2) hoist with load of 300 Kg in a maximum projecting position (pos. N)

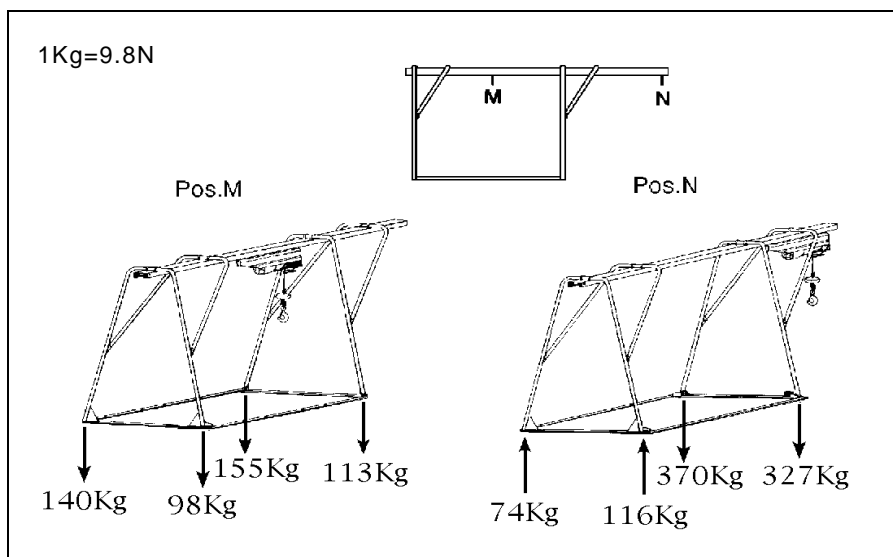

Based on the dimensions and type of load to be lifted, the device must be installed so that the load does not strike against other moving bodies or against stationary parts of the adjacent structures during the lifting and lowering movement.



The user must take all the necessary precautions, regardless of the type of installation created, to protect himself against the risk of falling.

In particular, the user must strictly comply with the following instructions:

a- The scaffolding of the mountings must be sufficiently wide and, on the sides towards the empty space, equipped with a normal guard and toe board.

b- An opening may be left to pass a shovel or bucket provided that a toe board with a height of no less than 30 cm is installed at that point. The opening must be reduced to what is strictly necessary and delimited by strong and rigid side supports, for which the one opposite to the pulling position must be additionally protected with fixed scaffolding elements.

c- Two iron brackets, projecting at least 20 cm, must be applied on the inner side of the supports described above, at a height of 1.20 m and perpendicular to the opening, which will be used as a support and guard for the worker.

d- The boards of the single shelves must be formed with planks with a thickness of no less than 5 cm which must rest on the cross members and have a section and centre distance that are sized in relation to the maximum load foreseen for each of the shelves.

START-UP AND USE



The machine should only be used by workers 14 years of age or older with an average skill level. It is recommended to use the machine in areas that are adequately illuminated.

In any case, check that:



a) the electric power supply corresponds to what is indicated on the rating plate attached to the casing of the electric motor;

Legend	
Type	Model
No.	Serial number
V	Power supply voltage
Hz	Frequency
rpm	Revolutions per minute
I.C.	Insulation class
A	Current intensity
KW	Power
CLASS	Class
C	Condenser capacity
DUTY	Load condition

BETA	CE
BETA ELEVATORI s.r.l. Via Edison 5 - 42040 Caldero RE	
Type	<input type="text"/>
N=	<input type="text"/>
CLASS	<input type="text"/>
SELF BRAKING MONO-PHASE MOTOR	
Y	Hz <input type="text"/> rpm <input type="text"/> I.C. <input type="text"/>
A	Kw <input type="text"/> c <input type="text"/> mF DUTY <input type="text"/>
MAX HANGING LOAD Kg	

Legend	
Type	Model
No.	Serial number
V	Power supply voltage
Hz	Frequency
rpm	Revolutions per minute
I.C.	Insulation class
A	Current intensity
CLASS	Class
KW	Power
DUTY	Load condition

BETA	CE
BETA ELEVATORI s.r.l. Via Edison 5 - 42040 Caldero RE	
TYPE	CLASS
N=	<input type="text"/>
SELF BRAKING THREE-PHASE MOTOR	
rpm	Hz <input type="text"/> I.C. <input type="text"/> DUTY <input type="text"/>
Kw	Y _Δ <input type="text"/> A <input type="text"/> Y _λ <input type="text"/> A <input type="text"/>
MAX HANGING LOAD Kg	



b) the outlet used is the safety type and that it includes a ground pin that comes in contact with the pin on the plug supplied with the device;



c) the outlet is connected to an efficient ground system and that it is fed by an electric plant protected by a residual current circuit-breaker and high-sensitivity magnetothermal switch (0.03A), all coordinated to conform with the prescriptions set forth

by UNICEI EN 60204/1 Sept. 93 (see attached circuit diagram). The switch must be installed on the power supply line prior to and in the vicinity of the machine;



d) the power supply cable section is adequate for the length of that cable to avoid an excessive voltage drop that might lead to malfunctions.

Indicatively, a section of 2.5 mm² should be used for distances of less than 30 m.

For greater distances, use cables with a section that is greater than or equal to 4 mm².

The hoist is controlled through a special control panel which includes two SALITA-DISCESA buttons as shown in the following diagram:

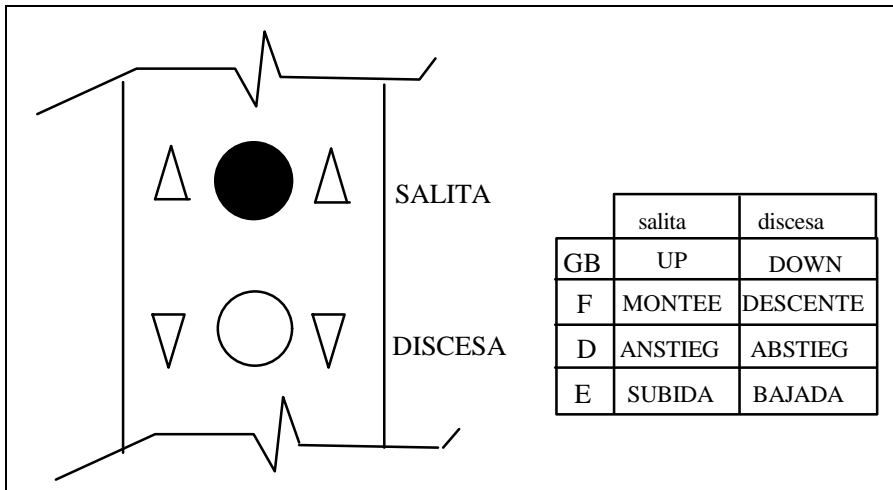

For the three-phase asynchronous motor version, check that the load is in fact lifted by pressing the corresponding “SALITA” (UP) button located on the push-button panel.

If this does not occur, switch the two phase wires in the power supply outlet.

A machine (lifting-lowering) test cycle must be performed (under no load and then rated load conditions), checking that the lifting limit switch operates correctly and that the stand is stable.

Check that the lifting limit switch operates correctly at the beginning of each work shift.

The load braking system must be checked every six months and, in any case, each time that, during normal machine use, the load does not stop immediately.



It is absolutely prohibited to disassemble or access the internal parts of the hoist without first cutting off the power supply by pulling the plug out of the power outlet.

The operator must work in a safe position, i.e. so that he is protected against falling and so that he has an unobstructed view of the trajectory of the moving elements.

If the operator uses safety belts to protect himself against falling, they must be anchored to fixed parts and absolutely immovable.



The hoist stand or any other part of the machine support structure cannot be used as an anchor point for safety belts.

- Access to the area underneath the vertical axis of the load must be prohibited to persons or at least a sign must indicate the danger due to suspended loads.

The user must still check that there are no persons in the area underneath the vertical axis of the load.



The loads must be lifted with a vertical pull and therefore it is prohibited to use the hoist with an oblique lift.

- It is recommended to sling the load perfectly and to use adequate containers for liquid or sandy substances.

- It is prohibited to use the lifting cable to sling the load (see drawing).

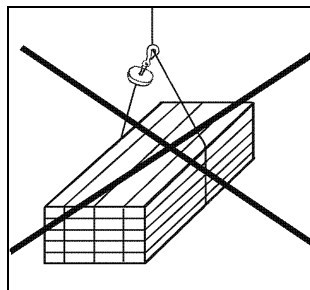

- It is prohibited to grab or touch the lifting cable while lifting or lowering the load, in particular near the lifting limit switch.

- The machine is built with an IP44 motor meaning that it is protected against solid bodies with sizes that are greater than one millimetre and against water infiltration in all directions.

Therefore, it is prohibited to use the machine in environments that are saturated with gas or if exposed to direct streams of water or rain.

- It is also recommended to:

a) avoid overloading the hoist;

b) stop the lifting movement before the limit switch trips since it should only be used in case of emergency;

c) check that the voltage does not decrease excessively during the start-up phase (this may prevent the brake from opening);



d) make sure that the cable does not completely unwind; at least 2 turns of the cable must remain on the drum to avoid damage due to the direct action of the load on the clamp that attaches the cable.

The cable wound on the hoist drum has a length that is greater than the maximum foreseen use height.

e) The cable maximum winding diameter must guarantee a free space on the sides of the drum equal to 1,5 times the cable diameter.

f) place the rotation shaft of the cable winder drum in a horizontal position to guarantee that the cable will be correctly wound on the drum.

Note: The manufacturer declines all responsibility for injury to persons or damage to property as a result of non-compliance with the above-mentioned standards.

MAINTENANCE

The entire device is built with class A4 which corresponds to 84000 operating Cycles.

The mechanism are built with class M4 which corresponds to 3200 h of operation.

After the number of operating cycles described above, the machine must be overhauled at a Nuova BETA authorised service centre.

The machine must be periodically inspected (on a six-month or yearly basis) to check the general use conditions (e.g. leaking grease, condition of electric power supply cables and machine control components, condition of the support structure, etc.).

In particular:

- The cables must be checked every three months and replaced immediately if there are any breaks in the elementary wires, or if they are twisted, smashed, bent, if knots have formed or if there is any other serious deterioration (heavy rust formation) or if heavily worn.

- The above-mentioned inspections must be reported on a special chart (see page 16), indicating the date of the inspection and the signature of the tester.

- The braking system must be checked every six months and, in any case, each time that, during normal machine use, the load does not stop immediately.

- The distance between the brake disk and electromagnets is adjusted using the set nut located at the end of the motor shaft.

It must range between 0.3-0.5 mm.

- The cable, hook and braking system register must be replaced by skilled personnel or at a BETA service centre.

REPAIRS

Repairs may be performed at a BETA service centre.

The user can request a list of authorised service centres at any time from dealers or directly from the manufacturer.

REQUEST FOR SPARE PARTS

A special manual includes tables with the drawings and the names of the various parts of the hoist. The code number is indicated next to the name of each part.

The request for spare parts must be submitted to a BETA service centre or to a dealer.

It must include the following:

- a) hoist model and serial number;
- b) piece position number or relative code;
- c) quantity requested.

STAND CHARACTERISTICS

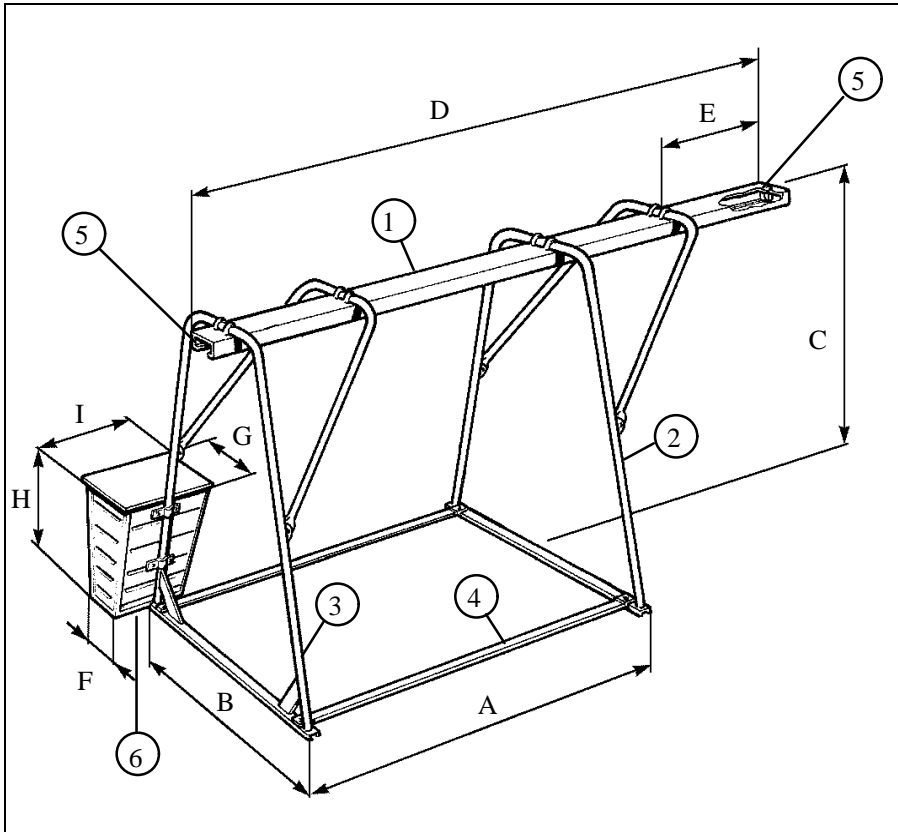

DIMENSIONS	POS.	NAME	Qty.
A = 2160	1	DOUBLE RAIL	1
B = 1520	2	FRONT ARCH	1
C = 2065	3	REAR ARCH	1
D = 3305	4	TIE RODS	2
E = 385	5	PLUGS	3
F = 285	6	BALLAST CONT.	2
G = 520			
H = 860			
I = 645			